

# ROTATING & TRAVERSING CRASHWORTHY SEAT

*Floor Mounted Seat for Operator, Gunner, or Medical Personnel*



- Only seat to provide crash protection in all orientations
- Rotates for forward, side or aft facing orientation
- Tracks forward/aft or inboard/outboard
- 30+G crash attenuation for the full occupant range
- Long mission comfort & endurance
- Triple Inertia Reel System



East/West, a woman-owned small business, was established in 1968 for the purpose of designing and manufacturing safer, more reliable, quality products for the US Government and the Aerospace Industry. Our outstanding performance has been recognized with awards by many of our customers.

## EAST/WEST

AN INNOVATIVE COMPANY

2002 Orville Drive North

Ronkonkoma, NY 11779

Tel: 631-981-5900 • Fax: 631-981-5990

[info@eastwestindustries.com](mailto:info@eastwestindustries.com)

[www.eastwestindustries.com](http://www.eastwestindustries.com)

AS9100 / ISO9001

CERTIFIED

**SINCE 1968, SAVING AIRCREW LIVES IS OUR FIRST CONCERN**

## DESIGN FEATURES

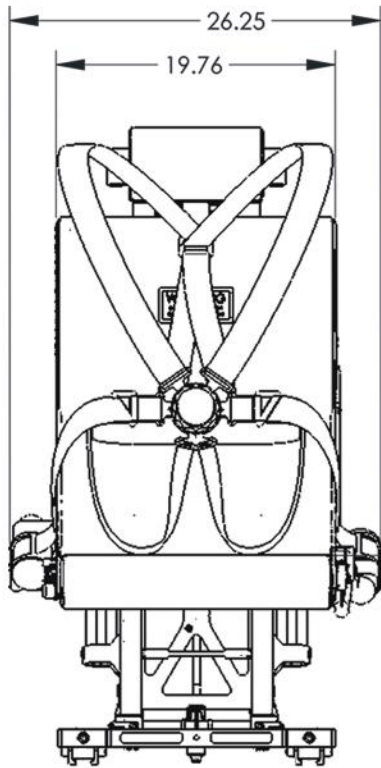

- Cushions are high-comfort, light-weight, and durable
- Harness improves occupant loads paths & retention
- Restraint system provides 40" of webbing payout at lap and 60" at shoulder
- All 3 reels are operated by a single control lever for improved safety and ease of use
- Weight: 83 pounds
- 9 inches of available stroke

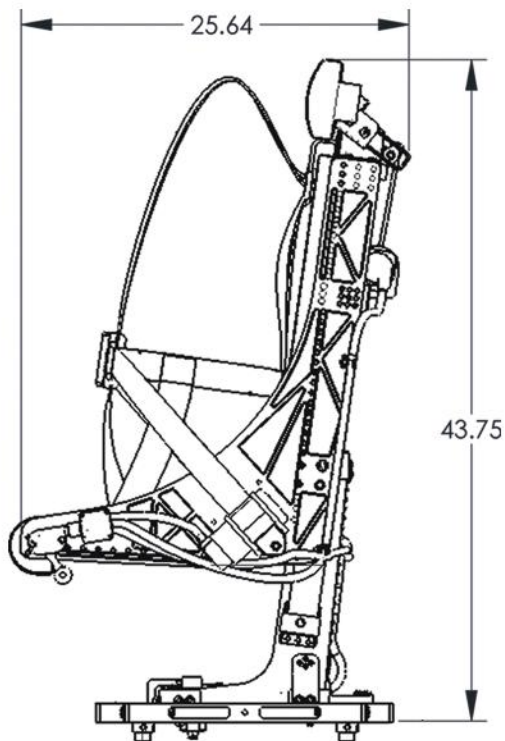

## QUALIFICATION TESTING

- Environmentally tested to MIL-STD-810G
- Dynamically tested in all orientations
- Extensive vibration testing



ROTATING & TRAVERSING  
CRASHWORTHY SEAT

