

# IMPROVED TROOP SEAT

*Selected by US Army for the CH-47 Chinook*



- 32 Inward facing troop seats
- Interchangeable at all locations
- 4-point Restraint System with rotary release
- Dynamic and static qualification for the full range of occupants
- Seat cushion adjustment of 4 inches for comfort or backpack accommodation



East/West, a woman-owned small business, was established in 1968 for the purpose of designing and manufacturing safer, more reliable, quality products for the US Government and the Aerospace Industry. Our outstanding performance has been recognized with awards by many of our customers.

## EAST/WEST

AN INNOVATIVE COMPANY

2002 Orville Drive North  
Ronkonkoma, NY 11779

Tel: 631-981-5900 • Fax: 631-981-5990

[info@eastwestindustries.com](mailto:info@eastwestindustries.com)

[www.eastwestindustries.com](http://www.eastwestindustries.com)

AS9100 / ISO9001  
CERTIFIED

**SINCE 1968, SAVING AIRCREW LIVES IS OUR FIRST CONCERN**

## DESIGN FEATURES

- Seat weight: 12.8 Pounds
- Fabric backrest provides optimum comfort while minimizing snag points (no large openings or holes like the legacy seat)
- Seat bottom is spring loaded for rapid and stowage
- Seat has stowable support leg
- Stowed position preserves cargo isle



## QUALIFICATION TESTING

- Seat is statically and dynamically qualified up to 12G
- Fully qualified to MIL-STD-810G environmental requirements

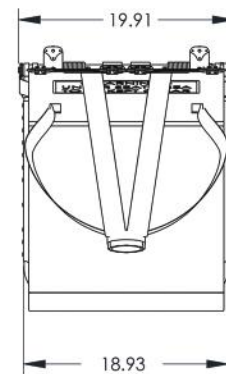
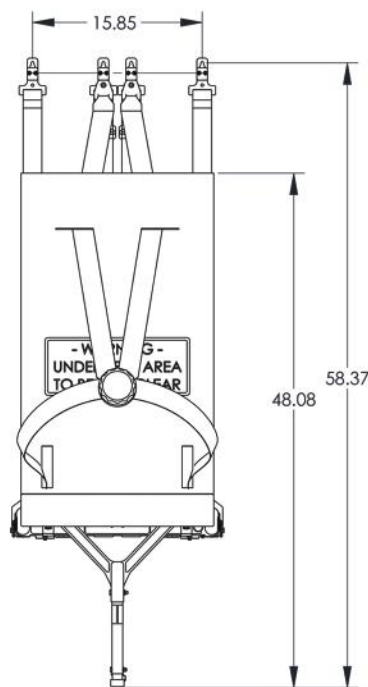
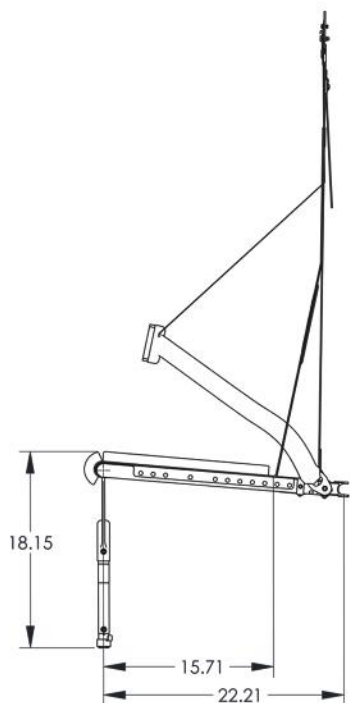

IMPROVED TROOP SEAT

