

CRASHWORTHY CEILING STOWABLE DUAL SEAT SYSTEM

*Selected for
Combat Rescue Helicopter*

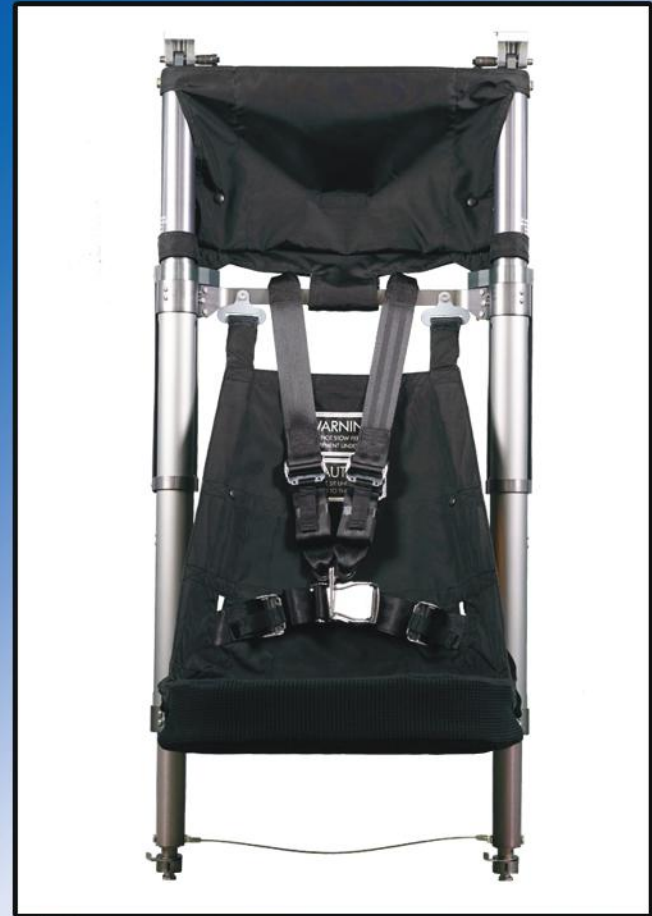

- Outward (side) facing
Seat system with ceiling mount
- Seat telescopes and stow to
ceiling mount for increased
clear floor space
- Seat attenuates 30+ G crash
pulse
- Ceiling mount for dual seats and
incorporates load bearing D-Rings



East/West, a woman-owned small business, was established in 1968 for the purpose of designing and manufacturing safer, more reliable, quality products for the US Government and the Aerospace Industry. Our outstanding performance has been recognized with awards by many of our customers.

EAST/WEST

AN INNOVATIVE COMPANY

2002 Orville Drive North
Ronkonkoma, NY 11779
Tel: 631-981-5900 • Fax: 631-981-5990
info@eastwestindustries.com
www.eastwestindustries.com

AS9100 / ISO9001
CERTIFIED

SINCE 1968, SAVING AIRCREW LIVES IS OUR FIRST CONCERN

DESIGN FEATURES



- Seat has 4 point restraint system with lift latch buckle
- Seat pan has a high-density foam with wool covering for both comfort and Part 29 Flammability protection
- Headrest protects occupant during crash stroking
- Floor attachment has relief for airframe displacement

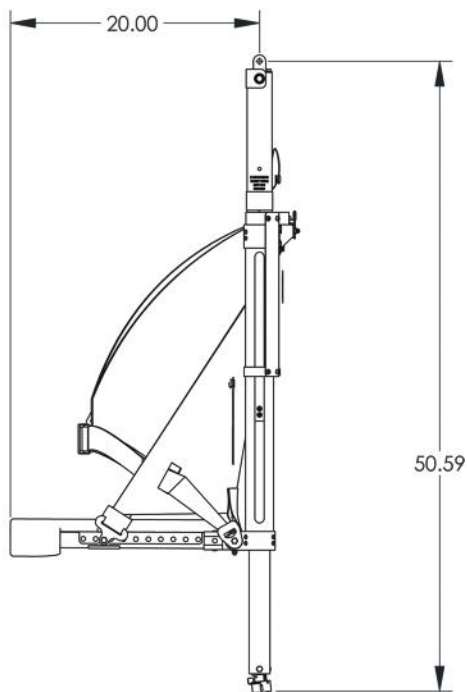
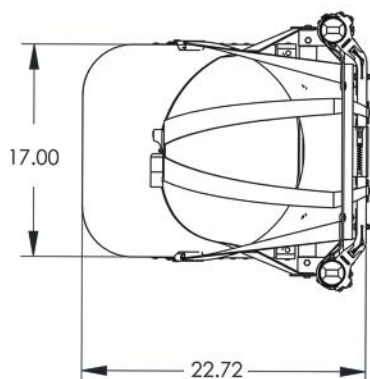

QUALIFICATION TESTING

- Environmentally tested to MIL-STD-810G
- Extensively Vibration Tested
- Dynamically and statically qualified for the full occupant range (small female to large male)



CRASHWORTHY CEILING STOWABLE
DUAL SEAT SYSTEM

