

# MOBILITY BOX TROOP SEAT SYSTEM

For the CH-47



- Mounted as a replacement of 3-Man Troop Seat System in all existing locations
- Crash resistant design
- Utilizes aircraft's existing 2-point restraint system
- Fully qualified to MIL-STD-810F environmental and vibration requirements
- Tested to crash requirements of three fully combat equipped occupants



East/West, a woman-owned small business, was established in 1968 for the purpose of designing and manufacturing safer, more reliable, quality products for the US Government and the Aerospace Industry. Our outstanding performance has been recognized with awards by many of our customers.

## EAST/WEST

AN INNOVATIVE COMPANY

2002 Orville Drive North  
Ronkonkoma, NY 11779  
Tel: 631-981-5900 • Fax: 631-981-5990  
info@eastwestindustries.com  
www.eastwestindustries.com

AS9100 / ISO9001  
CERTIFIED

SINCE 1968, SAVING AIRCREW LIVES IS OUR FIRST CONCERN

## DESIGN FEATURES

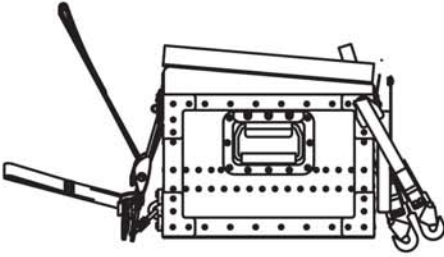

- Lid opens 90 degrees (min)
- Foam padding attached to lid with hook and loop fasteners
- Seat back webbing attaches to the outboard facing side of the base
- Handles; mounted to the fore and aft side of the base
- Lockable latches secure lid to base
- Strap assemblies secure box to 5k floor tie down rings
- Carabiner clips secure lower inboard side to 5k floor tie down rings
- Stowage bag for the seat back webbing when not in use
- Recessed center divider to allow stowage of long items

## QUALIFICATION TESTING

- Qualified to MIL-STD 810F environmental and vibration requirements
- Statically qualified for three fully combat equipped occupants

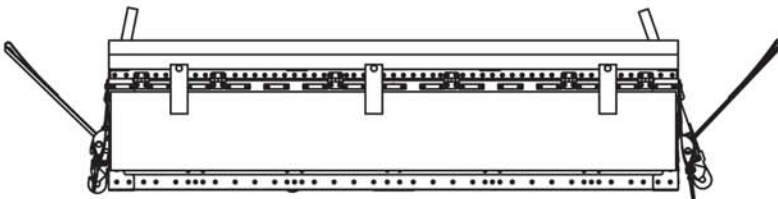
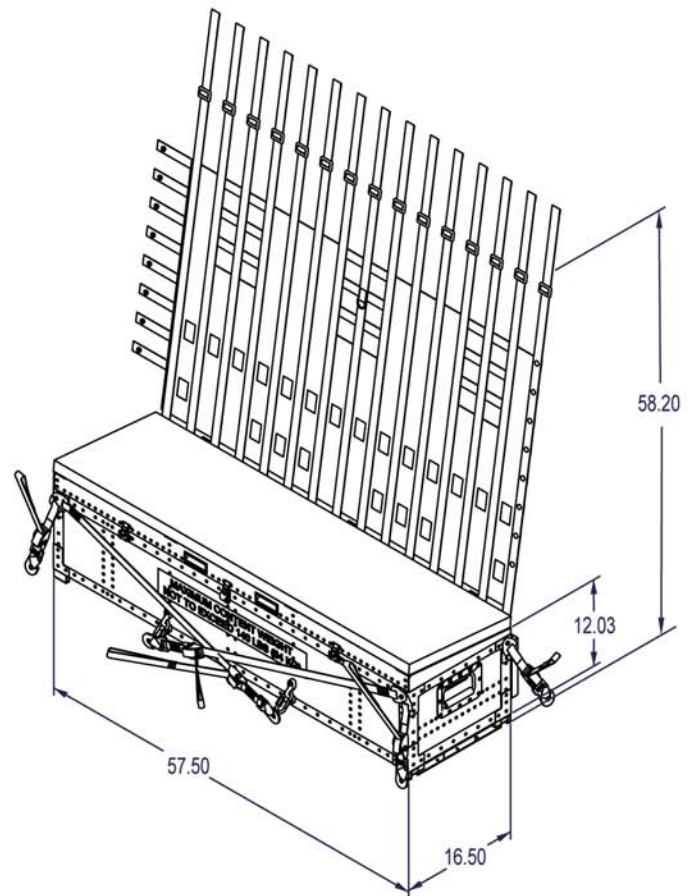

MOBILITY BOX TROOP SEAT  
SYSTEM

