

CRASHWORTHY UTILITY SEAT

Selected for the Bell 505 JRX Program



- Bulkhead mounted seat: fore or aft facing
- Lightest weight design
- Patented Energy Attenuator protects full occupant range
- 4-point lift-latch restraint system
- Certified to FAA TSO C127a Type B



East/West, a woman-owned small business, was established in 1968 for the purpose of designing and manufacturing safer, more reliable, quality products for the US Government and the Aerospace Industry. Our outstanding performance has been recognized with awards by many of our customers.

EAST/WEST
AN INNOVATIVE COMPANY

2002 Orville Drive North
Ronkonkoma, NY 11779
Tel: 631-981-5900 • Fax: 631-981-5990
info@eastwestindustries.com
www.eastwestindustries.com

AS9100 / ISO9001
CERTIFIED

SINCE 1968, SAVING AIRCREW LIVES IS OUR FIRST CONCERN

DESIGN FEATURES



- Bulkhead mounted
- Certified for forward or aft facing
- Lightest weight design
- Patented Variable Load Energy Attenuation System (VLEAS) protects full occupant range
- 4-Point lift-latch restraint system
- Installs/removes with two quick-release pins (less than 10 seconds)
- Stowable seat pan with retention strap (less than 6" deep)
- Designed to optimize occupant comfort
 - 1" thick wrap-around seat bottom cushion
 - Fabric backrest minimizes snag points
 - Evaluated to minimize vibration transmissibility
- Meets FAA 27.853a flammability requirements
- Seat cover and cushion in black, other colors available upon request

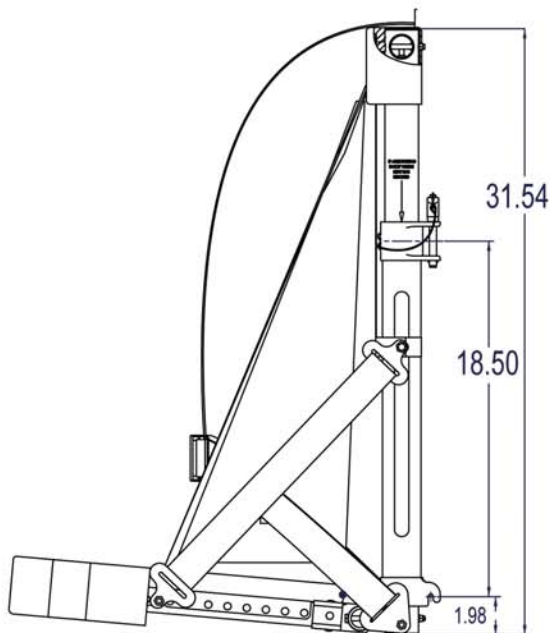
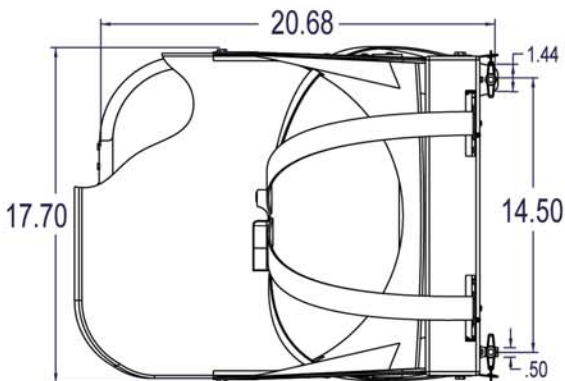

QUALIFICATION TESTING

- Certified to FAA TSO C127a Type B
- Dynamically and statically qualified
 - 170 lb. occupant
 - Forward facing
 - Aft facing
- Materials and Finishes are compliant with MIL-STD-810

CRASHWORTHY UTILITY SEAT

