

CRASHWORTHY TROOP SEAT

Selected for CH-53K and S-97 Programs



- Bulkhead mounted seat: fore, aft, or side facing
- Lightweight
- Patented Energy Attenuator protects 5th % female to 95th % equipped male occupants
- 4-Point lift-latch restraint
- Fully qualified to MIL-STD-810F environmental and vibration requirements
- Dynamically and statically tested



East/West, a woman-owned small business, was established in 1968 for the purpose of designing and manufacturing safer, more reliable, quality products for the US Government and the Aerospace Industry. Our outstanding performance has been recognized with awards by many of our customers.

EAST/WEST

AN INNOVATIVE COMPANY

80 Thirteenth Avenue

Ronkonkoma, NY 11779

Tel: 631-981-5900 • Fax: 631-981-5990

info@eastwestindustries.com

AS9100 / ISO9001

CERTIFIED

SINCE 1968, SAVING LIVES IS OUR FIRST CONCERN

DESIGN FEATURES

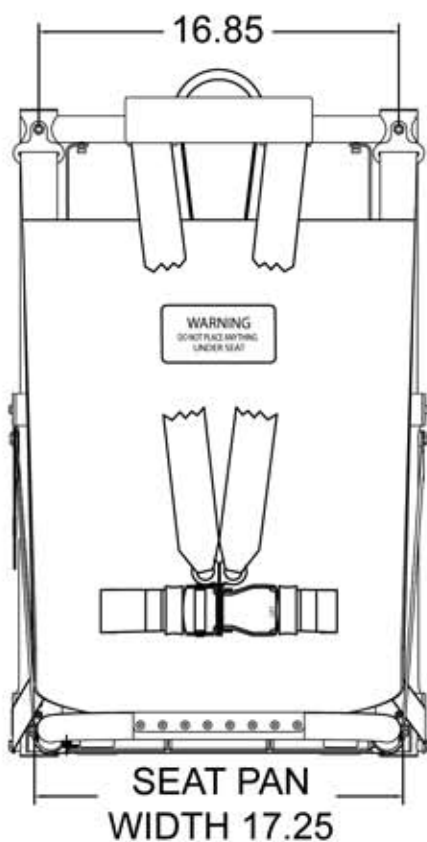

- Bulkhead mounted (accommodates 5° bulkhead warpage)
- Fore, aft, or side facing seat
- Lightweight
- Patented Variable Load Energy Attenuation System (VLEAS) protects from the 5th % female to the 95th % male occupants, requiring no user input for optimum protection
- 4-Point lift-latch restraint
- Single point handle for quick installation and removal of seat (less than 5 seconds)
- Stowable seat pan with retention strap (less than 6" deep)
- Fabric backrest provides optimum comfort while minimizing snag points
- Evaluated to provide minimum vibration transmissibility and optimize occupant comfort
- Meets FAA 25.853a flammability requirements

QUALIFICATION TESTING

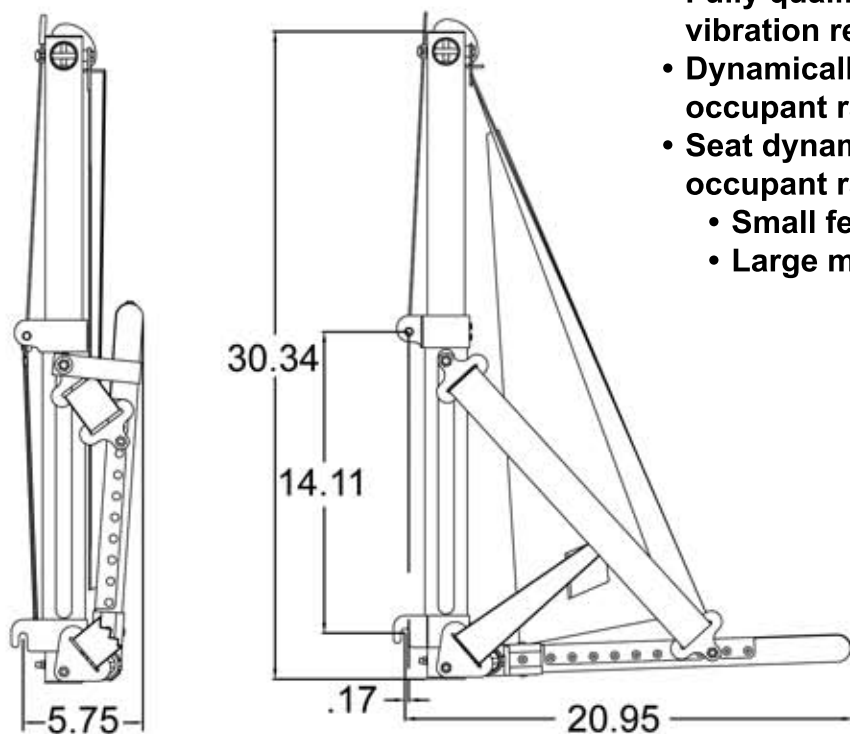

- Fully qualified to MIL-STD 810F environmental and vibration requirements
- Dynamically and statically qualified for a full occupant range
- Seat dynamically and statically qualified for the full occupant range
 - Small female (unequipped)
 - Large male (combat equipped)



CRASHWORTHY TROOP SEAT

